

Installation Guide: Tuff Span Insulated Panel System

Manufacturer's Assistance

These instructions are intended for a field-assembled, insulated system with Tuff Span liner and exterior panels with steel sub-girts. For further assistance, please contact:

Enduro Tel: 713-358-4000
16602 Central Green Blvd. Fax: 713-358-4100
Houston, Texas 77032 sales@endurocomposites.com

Material Handling

1. Inspect materials upon delivery. If damage is found, promptly advise both freight carrier and Enduro. Note damage on carrier's receiving ticket.
2. When lifting panels, use spreader bars. Do not use wire slings unless panels are protected.
3. Use planking when moving loads across panels. Do not overload or use panels for storage platforms.
4. Protect panels from surface cuts, impacts, and abrasions.
5. Avoid interference and extreme bending when covering corners, valleys, and uneven surfaces. **FRP materials cannot be reshaped by use of external force such as hammering or extreme bending.**
6. Use abrasive cutting tools or fine-toothed saws to cut panels.

Storage of Bundled Panels

1. Store bundled panels off the ground high enough to allow air circulation under the bundle and to be above standing water. Elevate one end of the bundle for water drainage.
2. Prevent rain from entering bundle by covering with a tarp or shelter. Avoid moisture between bundled panels, by providing air circulation between draped edges of tarp and ground.
3. If water is present in the bundle: Open the bundle, separate the panels, and dry the materials.
4. If conditions do not permit immediate installation, extra care should be taken to protect panels while nested in bundles against trapped moisture, which can cause permanent watermarks.

Liner Panel Installation

1. Install flashing that goes under liner panels first.
2. Make sure bearing areas are clean and free of projections. *Place liner panels with smooth surface toward inside of building.*
3. If specified, apply a continuous bead of butyl sealant tape between nesting side laps and before installing side lap fasteners (see Side Lap Detail on back).
4. **Use of proper equipment is critical to installation.** To drill pilot holes for Type A and B stainless steel screws use a 0-1000 RPM Variable Speed Drill and Carbide-Tipped Bit. *Impact or higher speed drills should not be used.* Refer to the Drill Bit Selection Chart for correct bit size. *Pilot holes are not required for SX5 or SX14 Self-Drilling screws.* To install stainless steel fasteners, use a 0-1000 RPM Variable Speed, Screw Gun equipped with clutch and depth sensing nose piece.
 - a. **For Type A and B stainless steel screws, drill pilot holes** through panels and into structural supports straight at very slow speed. High-speed drilling can harden inside of holes, making it difficult for fastener threads to bite and cause thread rolling. Excessive speed can cause drill bits to burn-up faster than normal. Applying a lubricant to drill bits can extend service life.
5. Fasten panels to supports at correct spacing with fasteners and washers as recommended on Page 2.
 - a. **Drive all screws at 500 rpm or less.** While installed, screws must be kept straight. Excessive speed may cause thread rolling

or shearing the fastener. To avoid excessive speed and heat build-up, "trigger" the motor (vary the speed).

- a. Tighten screws until sealing washer extrudes slightly beyond the metal washer as shown below. **Do not over tighten** screws as this can damage the fastener or panel.
- b. If thread rolling occurs, 1) apply a lubricant to screws, 2) make sure appropriate equipment is being used and these instructions are followed. Tapping the hole with a heat-treated Type B carbon screw with similar threads may be needed.
 - 6a. **For panel side lap attachment, Mark and drill a 3/8" diameter pilot hole** for the SB2 Grommet fastener at 18" o.c.
 - b. Before inserting the SB2, draw adjacent panels together to prevent premature spreading of the fastener.
 - c. Install SB2 fasteners using an adjustable torque driver at a slow speed. Tighten the SB2 until the grommet washer extrudes out slightly beyond the metal washer.
7. Install liner flashing with SB2 fasteners, 18" on center. Pilot holes are required for SB2 grommet fasteners.
8. Insert closure strips and secure them with fasteners or adhesive caulk (if condition is not suitable for fasteners).
9. Apply sealant tape and caulk where specified or shown on drawings. Surfaces must be clean and dry before application.

Sub-Girt Installation

1. Install sub-girts directly over existing structural girts. Sub-girts must be plumb, straight, and face the same direction.
2. Drill pilot holes in liner panel and sub-girt prior to installing structural fasteners. Fasteners should be located where sub-girt touches EVERY OTHER high rib of 4.1 x 9/16 liner panel. If liner panel is 2 1/2 x 1/2, location should be at every 3rd high rib.
3. Fasten sub-girt to structural girt through *liner panels* with stainless steel screws, long enough for a secure connection into the structural girt. Do not over tighten fasteners.

Exterior Panel Installation

1. Install insulation.
2. Install flashing that goes under panels first.
3. *Place exterior panels with embossed side to outside of building.*
4. If specified, apply a continuous bead of butyl sealant tape between nesting side laps and before installing side lap fasteners.
5. Drill pilot hole through panels and sub-girt (re: Liner Panel Installation step 4).
6. Fasten panels to sub-girts with Type "A" or "B" stainless steel screws with sealing washers at each low rib (see Liner Panel Installation step 5b. and 5c. for proper fastener installation).
7. Install side lap fasteners (see Liner Panel Installation step 6) at this spacing: 18" o.c. for siding and roofing with slope 3/12 or greater; 12" o.c. for roofing with slope less than 3/12.
8. Install flashing with SB2 fasteners, 12" on center.
9. Insert closure strips and secure them with fasteners or adhesive caulk (if condition is not suitable for fasteners).
10. Apply sealant tape and caulk where specified or shown on drawings. Surfaces must be clean and dry before application.

Cleaning and Repair

1. Clean panels with soap and water first. If this does not work, some solvents can be used to clean spills or stains on Tuff Span. However, solvents should be used sparingly and only if absolutely necessary. *Some solvents like acetone may remove the acrylic polymer surface coating on coated materials.*
2. Minor damage to deck or flashing can be patched with a Tuff Span repair kit. Materials with other damage should be replaced.

Correct Fastener Installation Visual Inspection

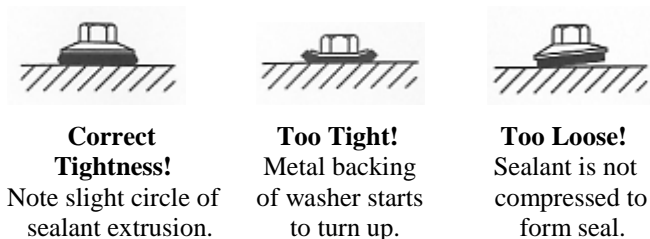

Selecting Fasteners

- Type A Point screws** (3/8" hex head): Used for fastening to wood structure, light gage metal (14 gage or lighter) and Tuff Span FRP structural members.
- Type B Point screws** (3/8" hex head): Used for fastening to steel members, 12 gage up to 1/2" thick.
 - Type A and B fasteners are available in 300 and 316 stainless steel or monel. These metals are softer than carbon steel; so extra care must be taken for installation.
 - Type A and B fasteners will include a .729" or 1.125" diameter metal and neoprene seal washer as required by specifications and structural requirements.
- SX5 Self-Drilling screws** (5/16" hex head): Suitable for fastening of panels to carbon steel members, 14 gage up to 1/4" thick. SX5 screws are available only in 304 stainless steel with S19, 3/4" diameter washers.
- SB2 Grommet** (5/16" hex head): Used to fasten flashing and panel-to-panel side laps. The SB2 is a grommet type fastener with a machine screw (300 and 316 stainless steel or monel), brass nut, and rubber sleeve.

Fastener Types

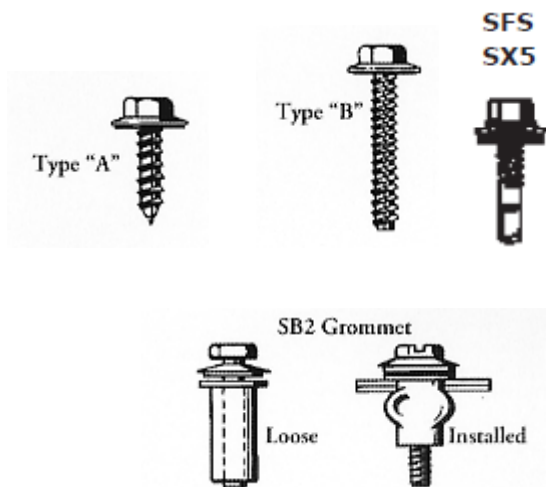

Tuff Span Insulated Panel System

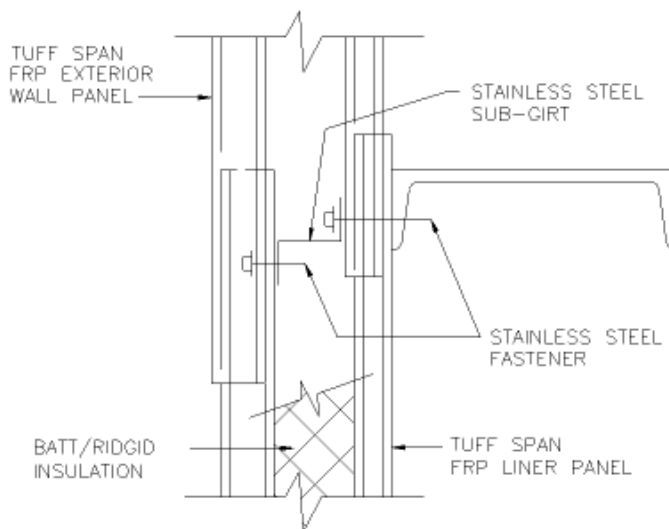

Panel Side Lap Detail

Place butyl lap tape at side-laps (if req'd) and not on top of ribs.

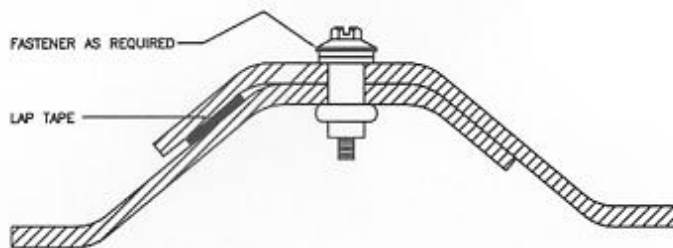

Drill Bit Selection Chart

Structural Fastener	Member Gage	Drill Bit Size
#14 Type B	.065-.085"	#8 (.199")
	.085-.115"	#7 (.201") or 13/64
	.115-.375"	#1 (.228") or 7/32
	.375-.500"	#1 (.228") or 7/32
# 14 Type A	.021-.026"	1/8 (.125")
	.027-.050"	3/16 (.187")
	.051-.075"	#8 (.199") or 13/64
	Wood	5/32"
	FRP	#22 (.157") or 11/64
SX5 Self Driller	.075-.157"	Not req'd
SX14 Self Driller	.158-.550"	Not req'd
#12XS Self Driller	FRP	Not req'd
Side Lap Fastener	Drill Bit Size	
SB2 Grommet	3/8"	