



Fabricated Structure Systems

Railings. Walkways. Ladders. Stairs. Mezzanines.



LONG-LASTING ACCESS SOLUTIONS THAT ARE ENVIRONMENTALLY FRIENDLY,
SUSTAINABLE AND ABOVE ALL, SAFE

Engineered Solutions That Outlast and Outperform

Creative Composite Group (CCG) supplies standard and custom Fiberglass Reinforced Polymer (FRP) composite handrails, guardrails, ladders, catwalks, and mezzanine access structures. Each structure is designed and fabricated based on governing codes and standards that are relevant to your industry, application, and specific requirements.

Customers receive our turnkey solutions that included design, manufactured parts, hardware and instructions. The product package arrives as a kit for simple installation. CCG handles the detail design and coordination so customers don't have to deal with designing a safety structure using commodity pieces.

There are many reasons why decision makers choose composites over traditional steel and aluminum structures. All materials of construction have their place, but the attributes for FRP composites make the material ideal for these access applications:

- light weight
- high strength
- corrosion resistant to chemicals
- long lasting and maintenance free
- non-conductive (electric and thermal)

Railings

FRP handrails and guardrail systems are designed specifically for each customer's requirements. Our systems work best in corrosive environments, such as chemical processing plants, wastewater treatment plants, and other challenging environments.

Ladders and Safety Cages

FRP ladder and safety cage ladder systems are ideal where safe vertical climbing access is required. CCG can develop a fixed ladder system to meet site-specific requirements. The products provide all the benefits above plus slip resistance.

Stairs

Stair systems are fabricated using FRP structural shapes and both molded and pultruded grating treads to create FRP stairways systems for company employees' safety and public pedestrian use.

Walkways

FRP walkways are long-lasting structures that can be supplied to meet demanding structural requirements and operate in corrosive environments. These can be used for pedestrian use or utility system supports.

Mezzanines

Mezzanines combine all the products above into a functional system that is cost effective.

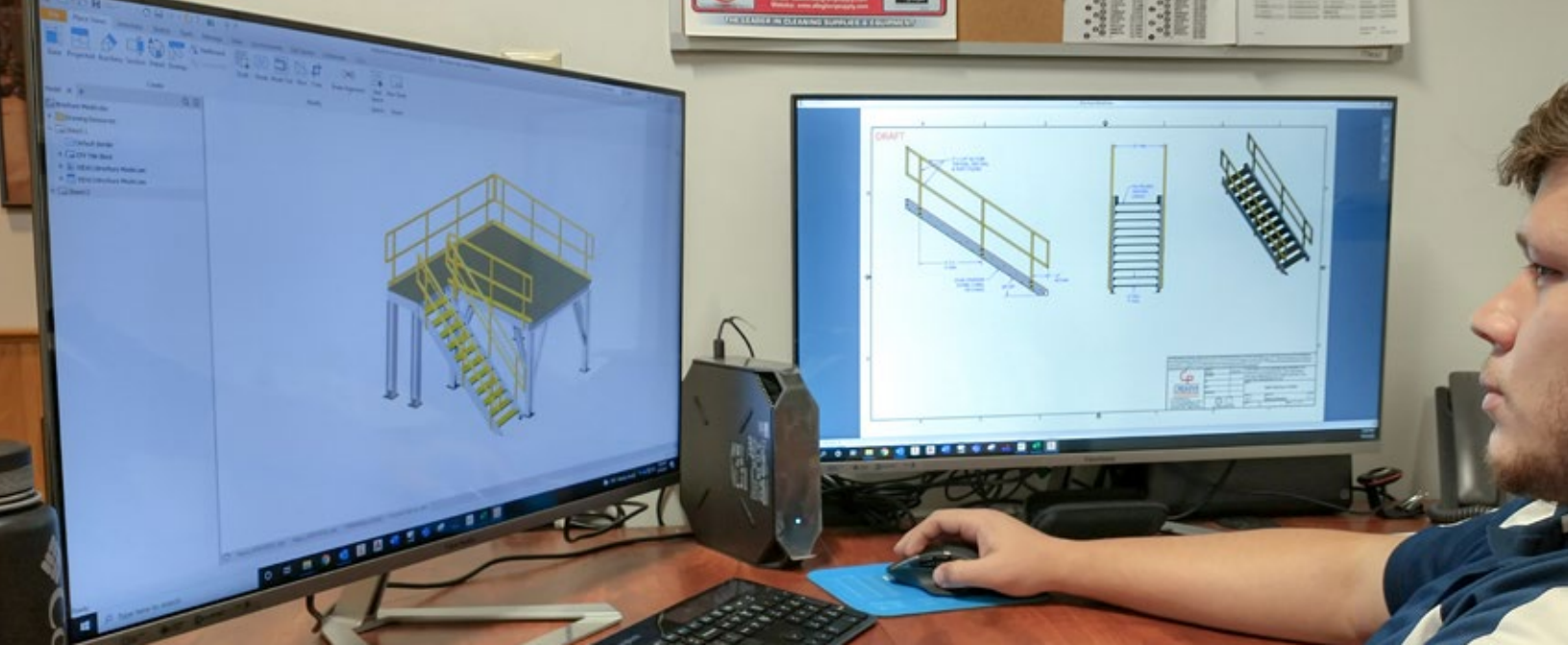

Design...Build...Deliver

The design flexibility of FRP technology means that fabricated structures can be exactly what you want. CCG safety structures are more than just commodity pieces bolted together. There is a comprehensive design process to ensure that the structures meet all your requirements. All aspects are performed by the CCG team. Design includes understanding all the requirements, performing detail calculations, and creating structural drawings. After customer approval, CCG draws on its inventory of pultruded profiles to machine and drill the sections for the structure. Parts are kitted for efficient transportation and assembly on site.

When customers contact us, our technical staff reviews the project scope in detail. We discuss timelines, budgets, expectations, application and relative codes and standards. We provide budget pricing, assist with specification writing, and provide a detailed quote. The exact action will depend on the stage of the project and the expectations that have been established between the customer and CCG to best assist with the project.

Pultrusion Process

The parts in the fabricated structures are pultruded profiles. Pultrusion is a continuous manufacturing process utilized to make composite profiles with constant cross-sections whereby reinforcements, in the form of roving and mats, are saturated with resin and guided into a heated die. Once in the die, the resin undergoes a curing process known as polymerization. The resin saturated reinforcements exit the die in a solid state and in the form of the cross section of the die. The pultrusion process requires little labor and is ideal for mass production of constant cross section profiles.

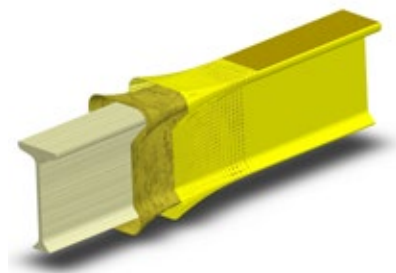

MATERIAL TYPES

Creative Composites Group offers three standard resin systems for the structural products:

- Isophthalic Polyester
- Isophthalic Polyester Fire Retardant (IFR)
- Vinyl Ester Fire Retardants (VFR)

CCG will make the proper resin selection based on structural requirements, cost and service conditions such as temperature, chemical environment and fire safety.

Access systems have been manufactured for 50 years under the Pultex® brand and are manufactured in an ISO 9001:2015 accredited design and production operation at Creative Composites Group's Pennsylvania facility.

Pultex® Guardrail & Handrail System

FRP handrail and guardrail are used where safety and corrosion resistant performance are critical. The Pultex® guardrail and handrail system will not rot, rust, or corrode. The system will reduce maintenance and future capex costs typically associated with metallic systems exposed to corrosive environments. All Pultex® guardrail configurations are designed to meet the Occupational Safety Health Association (OSHA) section 1910 minimal standards.

The Pultex® standard guardrail system consists of a 2"x1/4" top rail square tube, a 2"x1/4" mid-rail tube, 2"x1/4" vertical square tube post and kickplate. Starting with these standard shapes, CCG designs the guardrail system to the desired size, dimensions and loading requirements. Handrails are added to the guardrail systems when requested for maximum safety.

The system is available in all three resin types to address the operating environment most cost-effectively. The bright safety yellow resin formulation includes a superior UV additive that significantly decreases UV fading over time.

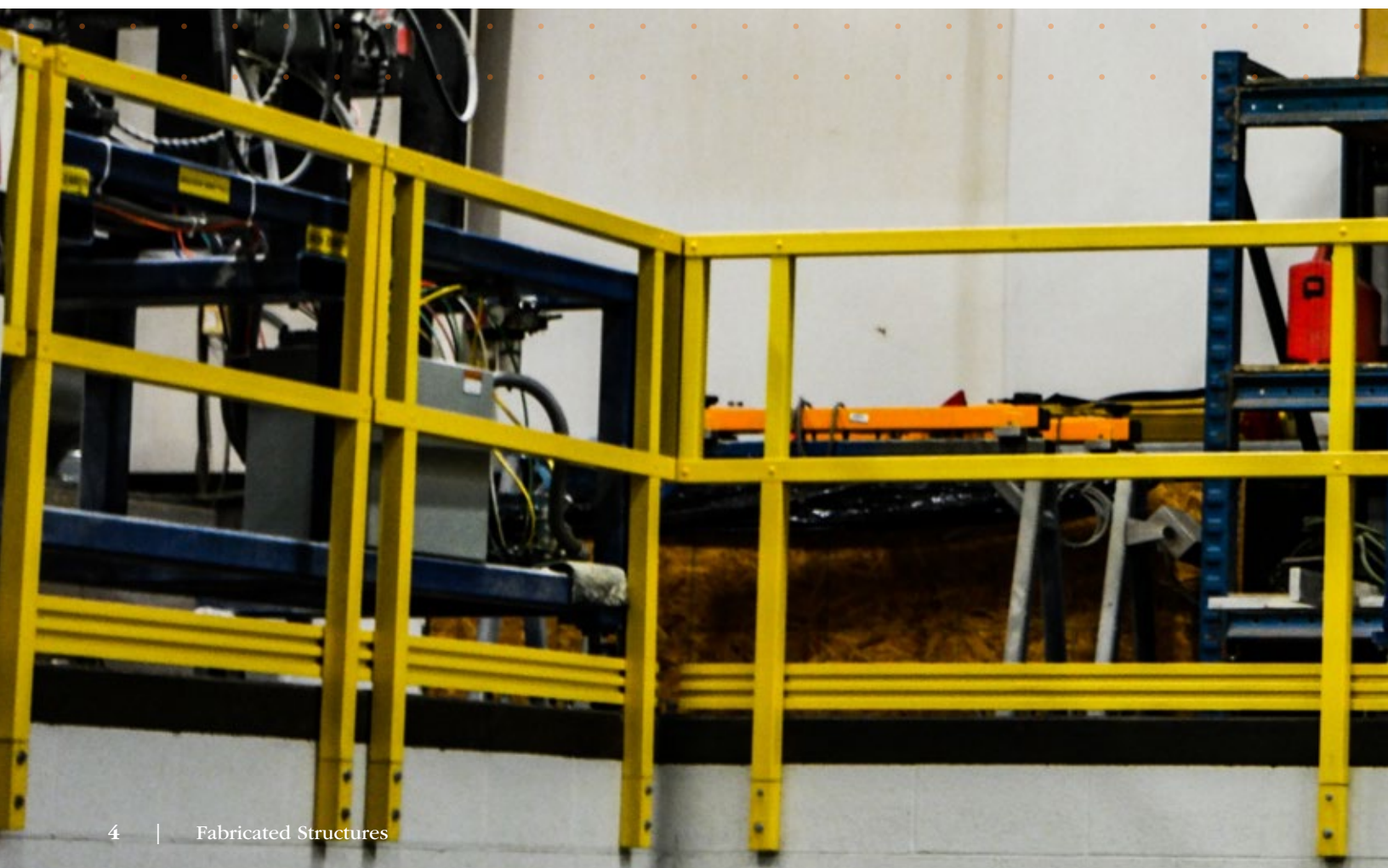



CCG guardrail designs address all the details to ensure an excellently functional system that is long lasting.

Details include:

- Tube connections,
- Kickplates, and
- Corner connections,
- Handrail connection.

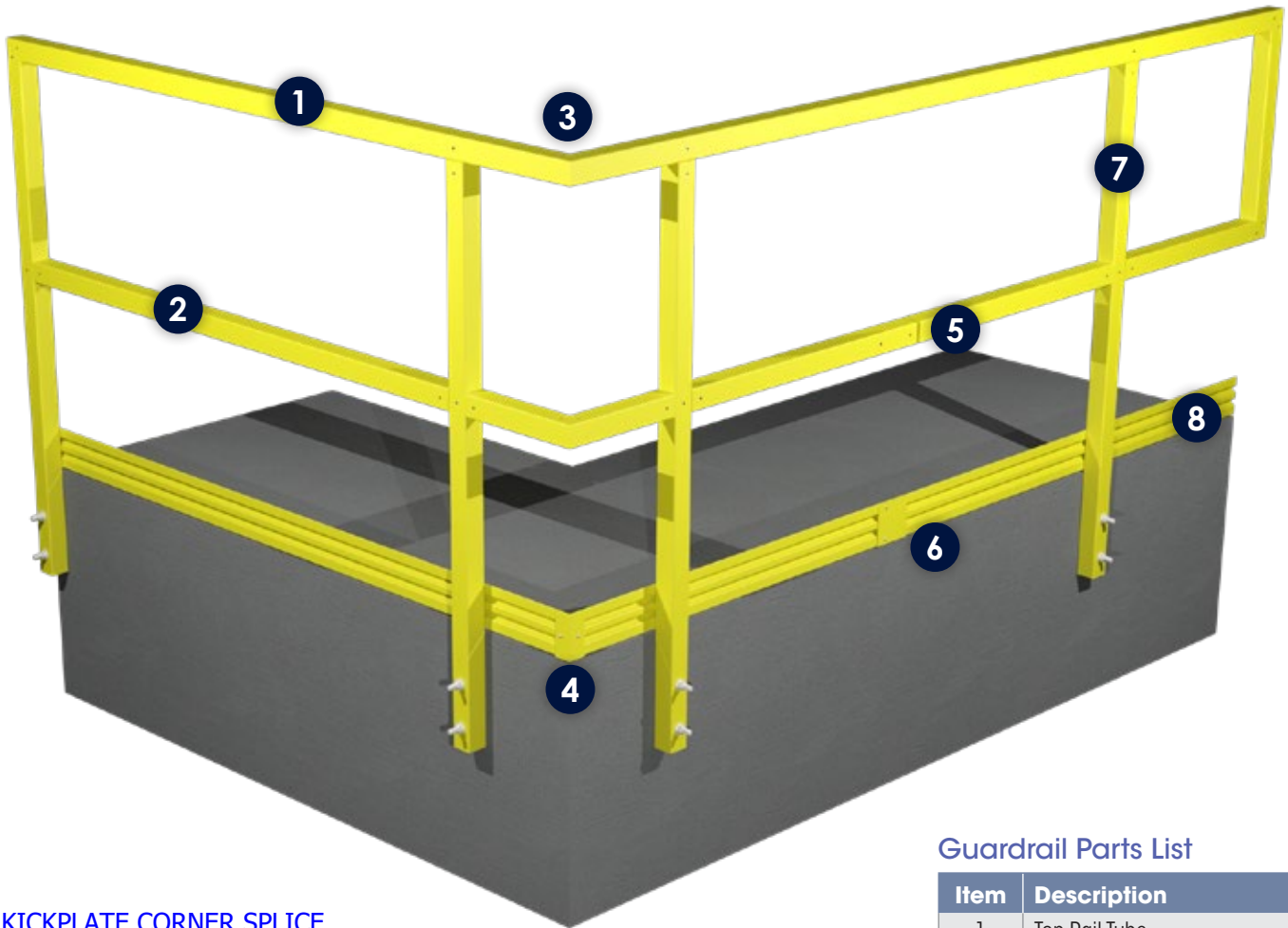

Guardrail Parts List

Item	Description
1	Top Rail Tube
2	Midrail Tube
3	Handrail Corner Connection
4	Kickplate Corner Splice
5	Tube Splice Connection
6	Kickplate Splice Connection
7	Vertical Post
8	Kickplate

KICKPLATE CORNER SPLICE

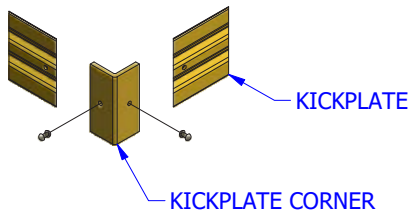

GUARDRAIL CORNER CONNECTION

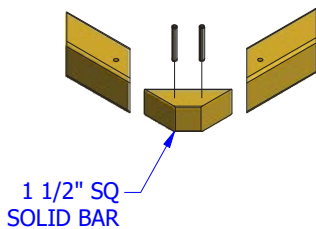

TUBE SPLICE CONNECTION

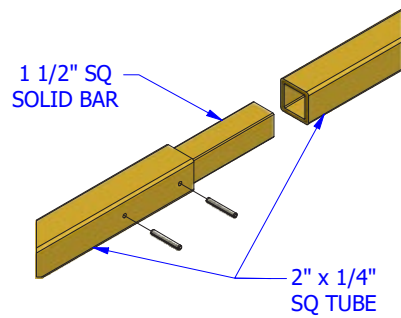

KICKPLATE SPLICE CONNECTION

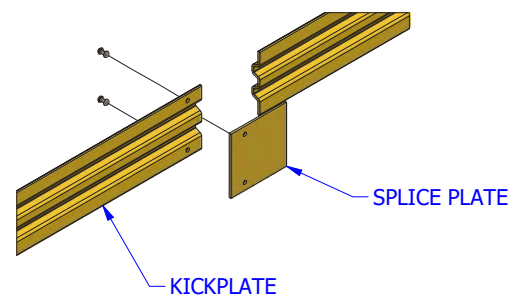

TYPICAL ADA RAIL CONNECTION

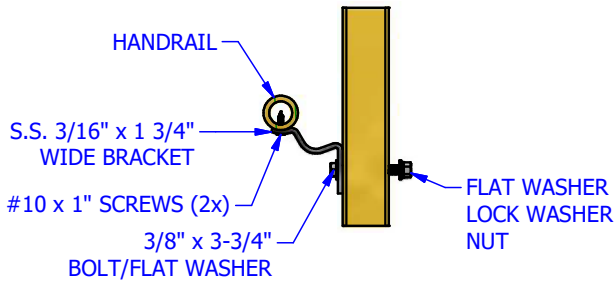

TOP AND MID-RAIL CONNECTION

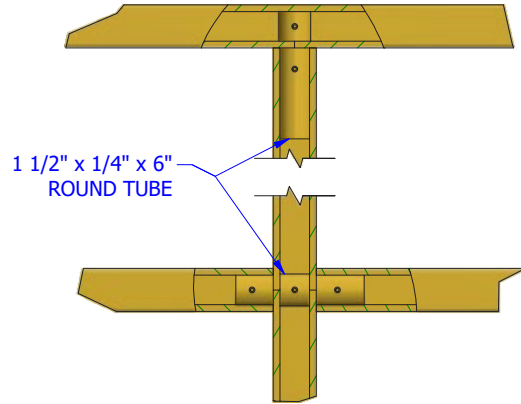

POST TO FRP OR STEEL CHANNEL

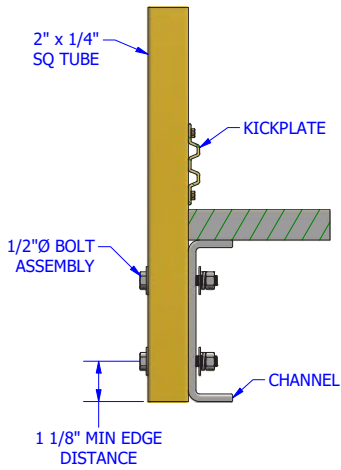

POST TO FRP OR STEEL BEAM

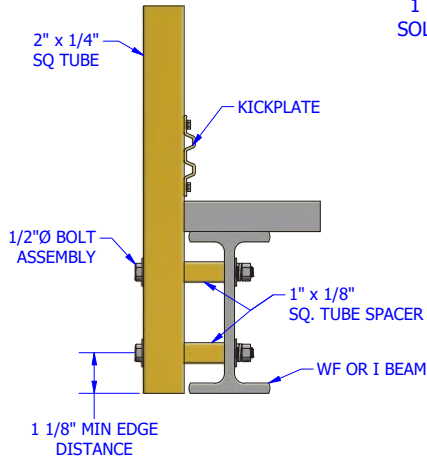

END POST TO RAIL

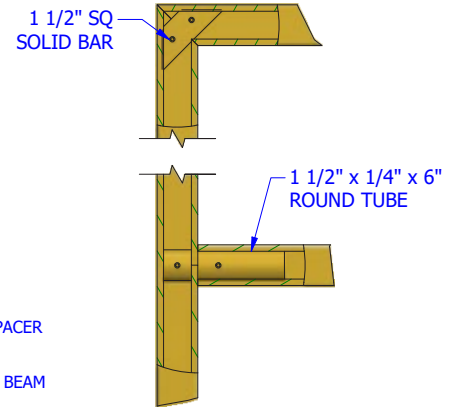

REMOVABLE CONC. SLEEVE MOUNT

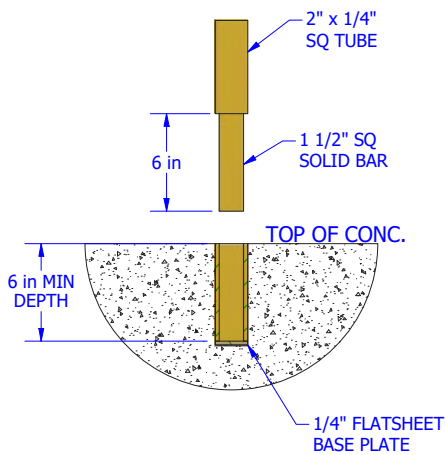

SIDE MOUNTED POST TO CONCRETE

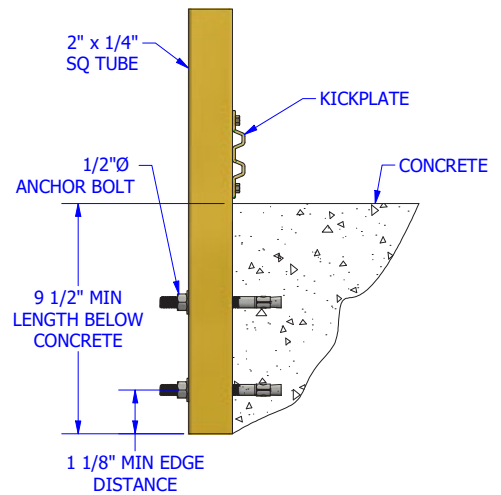

Pultex® Access Ladders

Pultex® access ladders are code compliant and ideal for applications that require corrosion resistance, superior dielectric strength, light weight and safety attributes. The FRP ladder and safety cage ladder systems are designed for use where safe vertical climbing access is required. Ladder systems consist of 2" x 2" x ¼" thick pultruded square tube for side rails. Fluted rungs are mechanically fastened using ¼" diameter stainless steel spring pins. A standard ladder width is 24", with the distance between rungs not exceeding 12". Fiberglass ladders require support back to a wall or structure at an interval of no greater than 6' 0". Standard fiberglass ladders are required to be base supported. Fluted rungs offer secure gripping and slip resistance. We routinely develop fixed ladder systems to meet site-specific requirements.

Our FRP Ladder systems are designed to withstand a concentrated load of at least 200 pounds at the mid-point of the rung. As a result, this exceeds the requirement of OSHA 1910.27, Fixed Ladders. For maximum safety, we can provide fiberglass ladders with safety cages to meet OSHA requirements.

Requirements:

- Safety cages must be on ladders of more than 24 feet in length and to a maximum unbroken length of 30 feet
- Must have an intermediate rest platform every 30 feet
- Safety cages must start at a minimum of 7 foot and a maximum of 8 foot above the finish floor
- Cages must extend 42 inches above the landing at the top of the ladder





Access Ladder Rendering & Connection Details

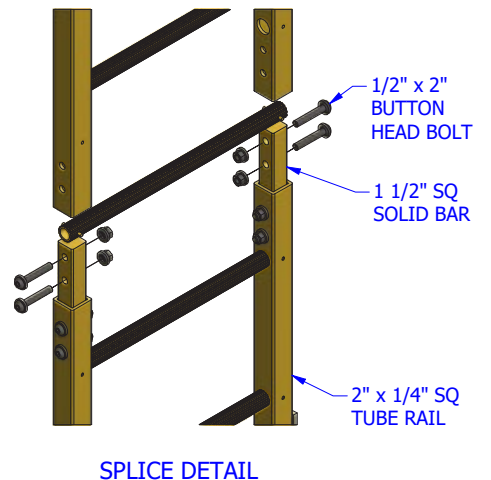
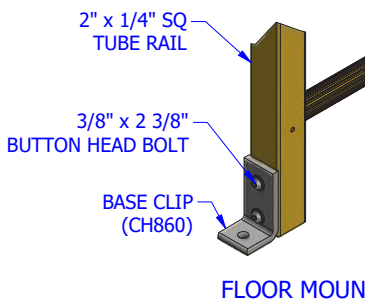
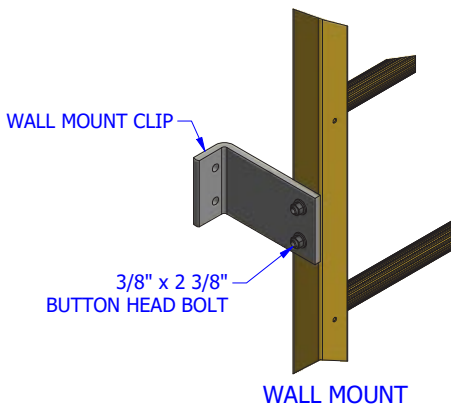
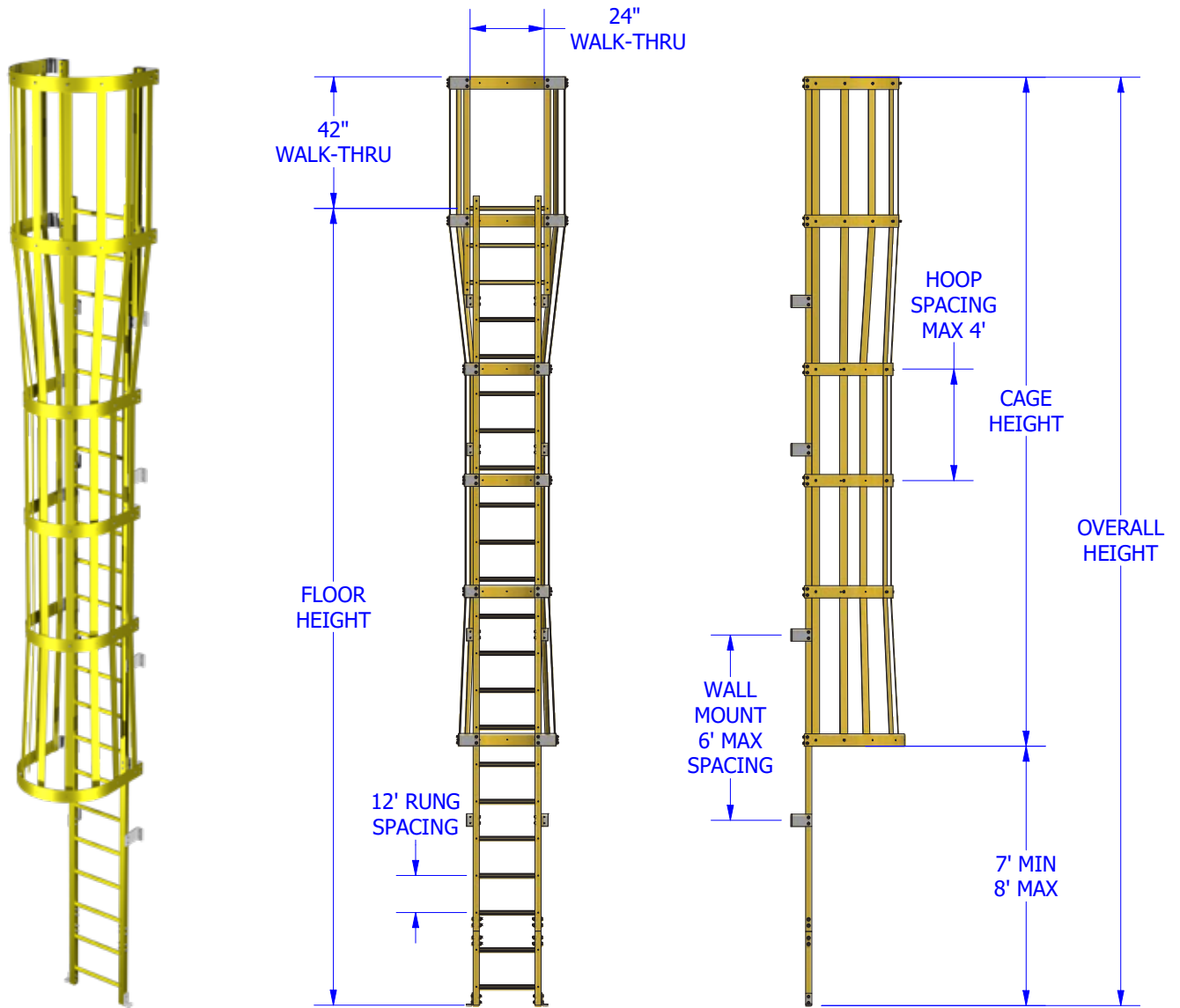

Pultex® Stair Systems

Our stair system is fabricated using Fiberglass Reinforced Plastics (FRP) structural shapes and FRP molded and pultruded grating treads to create FRP stairways systems for company employees' safety and public pedestrian use.

FRP stairway systems are designed, engineered, and custom fabricated in accordance with OSHA Standards, Section 1910.25, entitled "Stairways" and section 1910.28, entitled "duty to have fall protection and falling object protection." All stairway risers are equally spaced, and treads are the same size from the bottom to the stairway's top.

FRP stairway systems consist of channel stringers, tread support angles, attachment/anchoring angle clips, molded, and pultruded treads with nosing, square tube railing on both sides of stairways. Also, ADA railing is available and attached to the stairway railing inside. The structural elements are pultruded with a fire-retardant polyester or vinyl ester resin with a surface veil for protection against ultraviolet attack. Standard colors are dark gray, beige, and safety yellow.

Design flexibility accommodates variable project requirements like width and stair count. All assembly hardware is 316 stainless steel hex-head bolts and stainless grating saddle clips for treads. FRP stairway systems can be shipped fully, partially assembled, or entirely knockdown for the customer's field assembly.

We offer custom engineering and design capabilities with design submittal drawings for the customer to approve, and full shop drawings for custom fabrications.

The stair system is designed with easy field installation in mind to reduce construction time and cost. Our advanced fabrication technique delivers the highest quality FRP stairway systems.

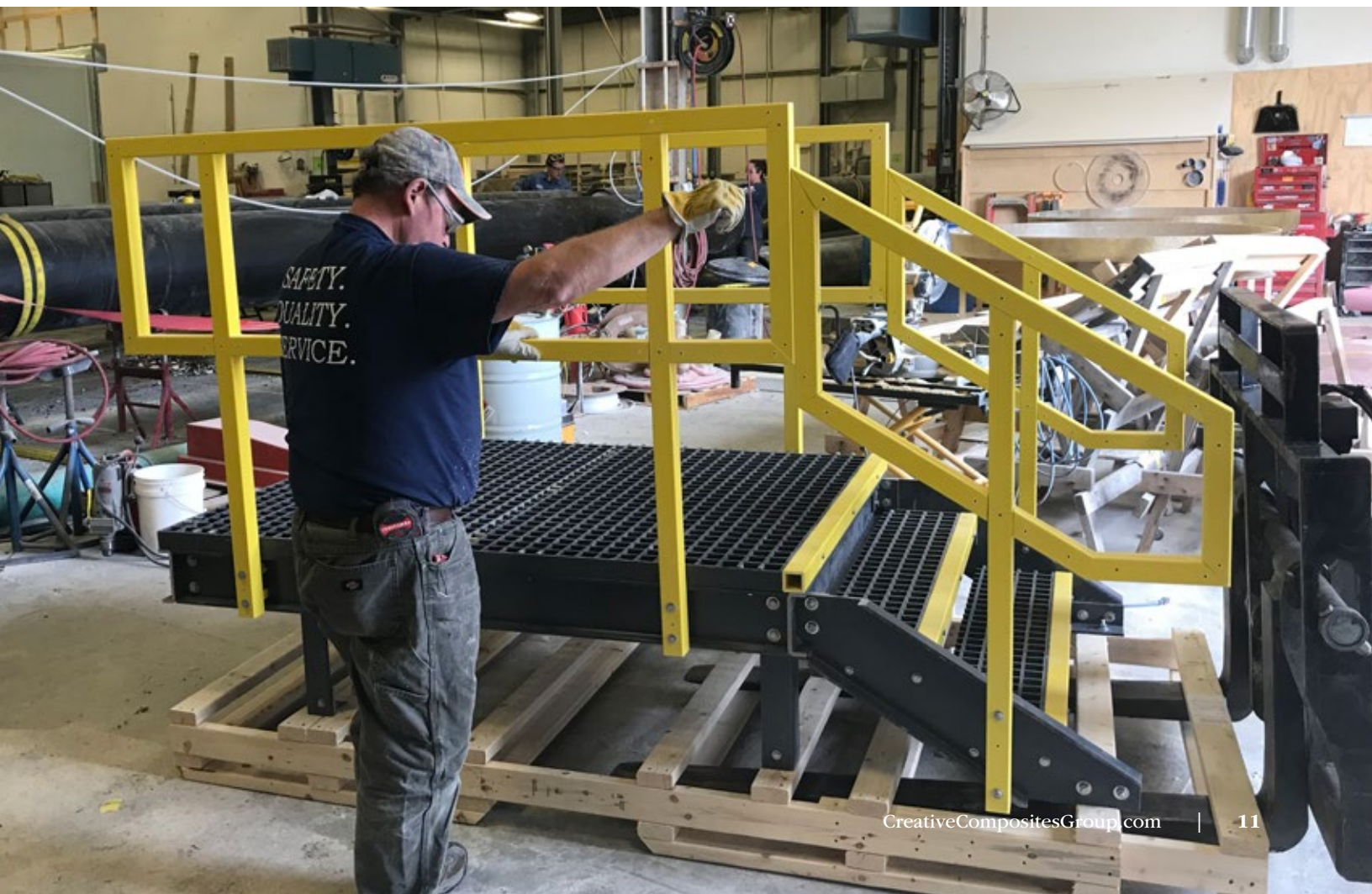

Stair Rendering & Connection Details

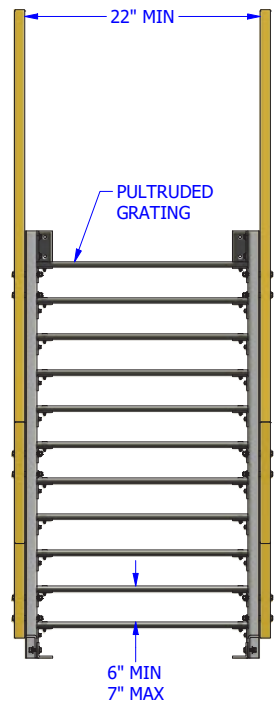
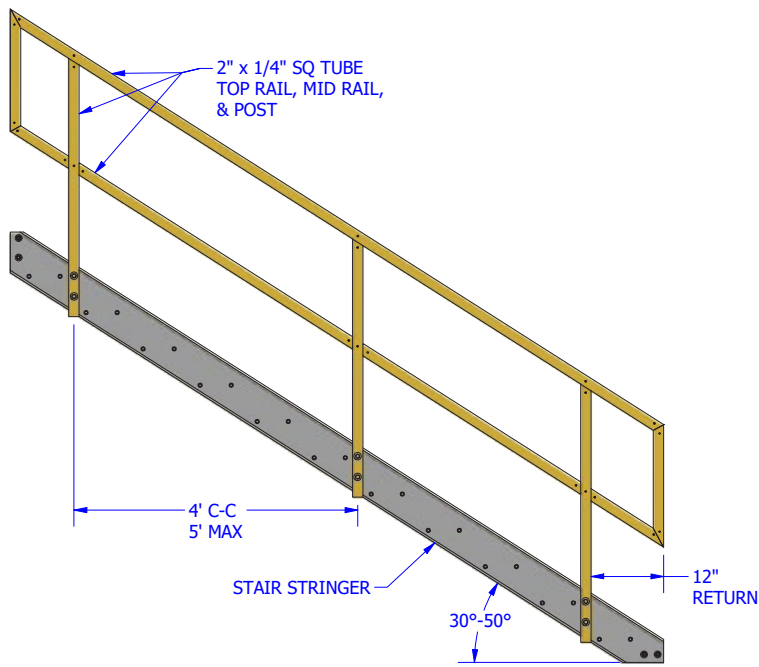

Pultex® Walkways & Mezzanines

Fiberglass walkways are long-lasting structures that can be supplied to meet demanding structural requirements and operate in corrosive environments.

Pultex® walkways and mezzanines are custom designed based on your dimensional, structural and application requirements. The custom designed structures are designed to be code compliant and easy to install. They are constructed of Pultex® standard and Superstructural® structural beams, channels, tubes and angles.

Superstructural® wide-flange and I-beams are constructed with an advanced fiber architecture with superior strength and stiffness properties above that of standard structural profiles. This attribute permits the engineer to design with longer spans and less beams creating a more economical structure.

Grating for Walking Surfaces

FRP grating is used for the surfaces of walkways, stairs, platforms, and other load-bearing structures. It is available in pultruded and molded forms, both of which can be customized to meet specific performance and safety requirements.

Pultruded fiberglass gratings are fabricated from corrosion-resistant I- or T- bars that are connected and secured through a unique notch and groove bar system. They are suitable for applications that require high strength and stiffness. Molded fiberglass gratings are molded and cured into the desired shape. They are ideal for structures that need extensive fabrication and cutting as well as applications that involve corrosive compounds or require a large open area.





Walkway & Mezzanine Rendering & Connection Details

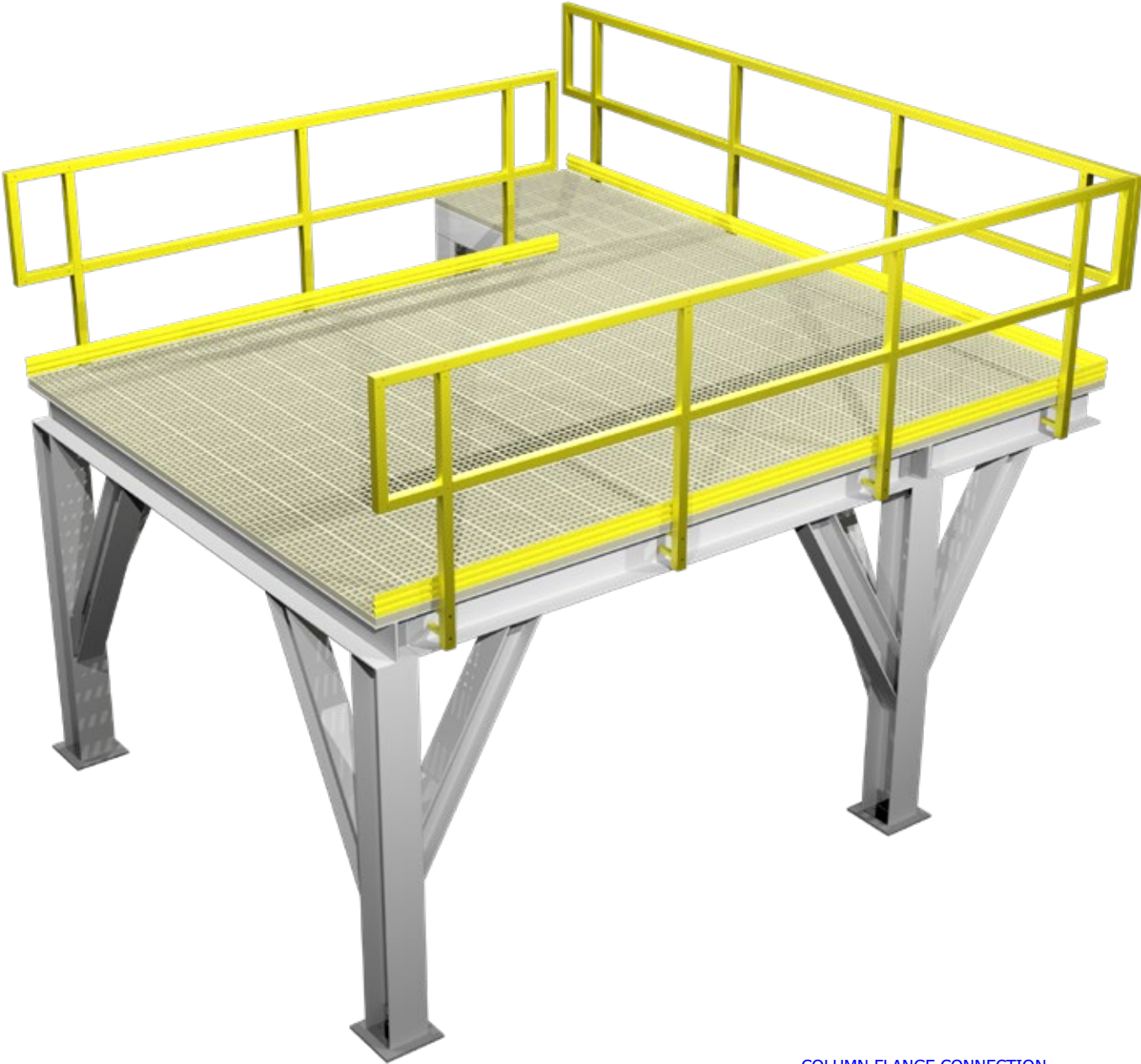

CHANNEL CONNECTION

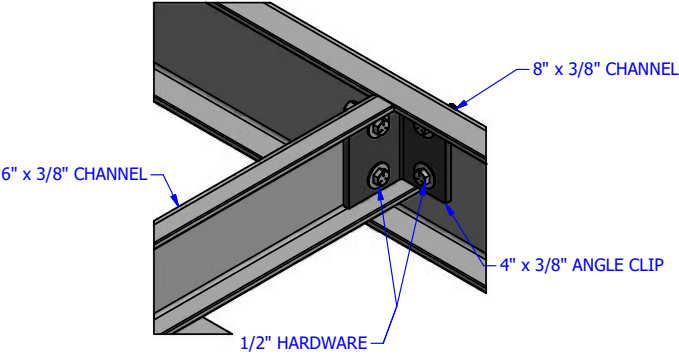

COLUMN FLANGE CONNECTION

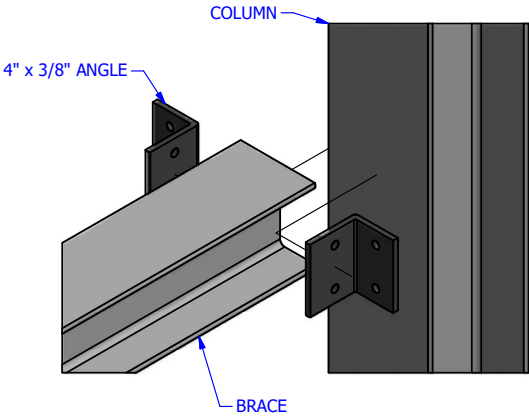

Choose Creative Composites Group for Comprehensive Project Support

Your Single Source for Innovative Fabricated Structures Using Fiber Reinforced Polymer Composites

Advance your products and projects beyond the limitations of traditional concrete, steel, and wood by leveraging the combined strength of Creative Composites Group. We are a leader in technical innovation that is backed by the industry's most comprehensive FRP manufacturing group.

As Creative Composites Group, we can help you engineer and manufacture fabricated structures to meet the needs of future generations.

Other companies commoditize FRP in off-the-shelf shapes and forms; Creative Composites Group does not. We offer comprehensive engineering, design and consultation for unique fabrication projects. Our manufacturing capabilities include the broadest range of engineered FRP solutions to build your ideal projects. That's possible only with our proven engineering processes, end-to-end collaboration, service and support resources. Since FRP composites last longer than conventional materials they often have a lower lifetime cost when you consider longer service life and low to no maintenance costs.

Discover Your Custom Engineered FRP Fabrication Provider

Creative Composites Group is committed to becoming a trusted business partner who is keenly interested in your project's success. Creative Composites Group works alongside your team, from facility owners to design engineers and contractors, to help you develop a customized FRP solution that meets the most demanding structural requirements and environmental conditions.

*Contact us for your next engineered FRP fabrication project.
We'd be thrilled to discuss it with you.*

CreativeCompositesGroup.com



Creative Composites Group

888-274-7855

214 Industrial Lane
Alum Bank, PA 15521

CreativeCompositesGroup.com

DLR101821R1
©2021 Creative Composites Group